

FEEL BETTER.  
TRAVEL FARTHER.

# SHOCKWAVE

MARINE SUSPENSION SEATING

## S5 | JOCKEY SEAT SW-S5-2400

 TRAVEL  
4" IN

The SHOCKWAVE S5 Jockey Seat offers solid performance in an affordable, light-weight and compact package. Equipped with a FOX Float H2O air sprung shock, it features on-the-fly adjustments for firmness and rebound rate. The seat cushions are made with closed cell foam and heavy-duty black fabric, well suited to recreational RHIB or commercial applications. Designed for comfort and durability in outdoor and saltwater conditions. The S5 Jockey is designed to mount on a seat riser storage box and is ideal for refits.



Riser Box and Grab Rail  
not included



- ✓ One of Our Most Compact Solutions
- ✓ Adjustable Firmness and Rebound Rate
- ✓ Designed for Comfort and Durability in Light to Moderate Sea Conditions



# S5 | JOCKEY SEAT SW-S5-2400

A cost-effective solution for commercial vessels and open RHIBs, the S5 Jockey is easily installed with simple rugged construction and minimal components. It absorbs wave shock and can contribute to preventing both high-impact and cumulative injury.



## S5 JOCKEY VESSEL & PRODUCT APPLICATION



Best suited to commercial, SAR & government agency vessels



Light and very compact, suitable for retrofits and new builds



Light to moderate ocean conditions, moderate speeds

## S5 JOCKEY ACCESSORIES



**FRONT GRAB RAIL**

SW-04732



**REAR GRAB RAIL**

SW-05476



**JOCKEY RISER BOX**

SW-08043

## S5 JOCKEY SEAT DRAWING

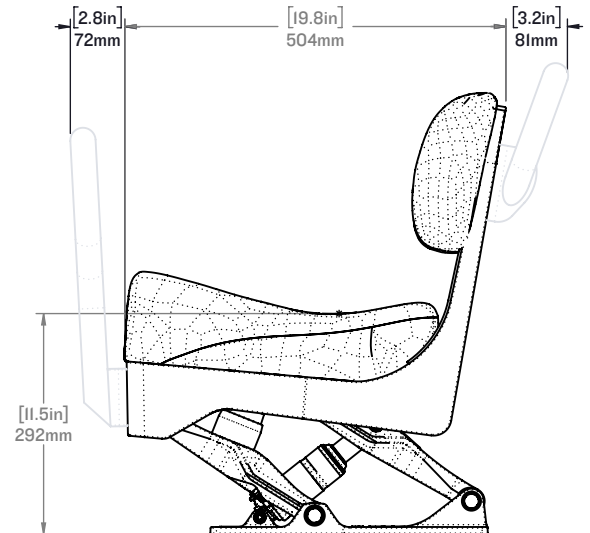
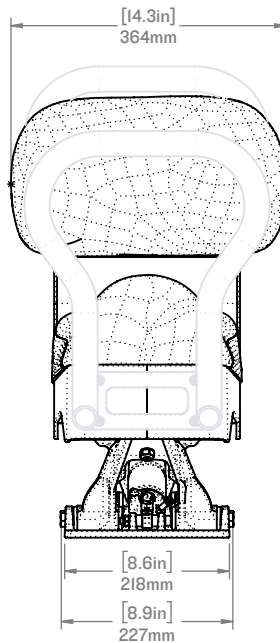
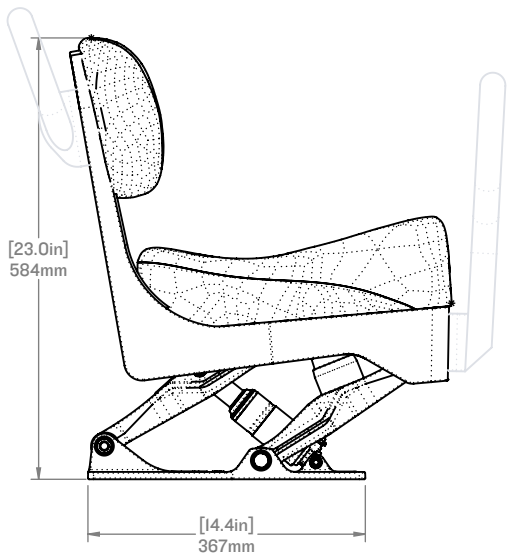

**PART ID:** SW-S5-2400 **WEIGHT:** [39.4lbs] 17.9 kg

[WWW.SHOCKWAVESEATS.COM](http://WWW.SHOCKWAVESEATS.COM)

✉ [sales@shockwaveSeats.com](mailto:sales@shockwaveSeats.com) ☎ 778-426-8545